

A Guide to the TracPhone F33 installation manual



Installation Notes

Before you install your TracPhone® F33 system, please read the important note below.



PLEASE READ!

Important Notice About Your Data Connection

To prevent inadvertent airtime usage, the user must disconnect the data connection when not in use. If the data connection is not properly disconnected, your computer may dial out on its own, which could result in an unintended airtime charge.

KVH accepts no responsibility if this occurs. It is the vessel owner's responsibility to ensure that the TracPhone F33 is correctly interfaced with the vessel's computer.

If you have any questions about data connections, please contact KVH Technical Support.

Thrane & Thrane A/S

TT-3088A Sailor Fleet33

Installation Manual

Copyright© Thrane & Thrane A/S

ALL RIGHTS RESERVED

Information in this document is subject to change without notice and does not represent a commitment on the part of Thrane & Thrane A/S. It is recommended to download the latest version of the manual from the Thrane Extra net or request this from the distributor.

© 2004 Thrane & Thrane A/S. All rights reserved. Printed in Denmark.

Document No: TT98-120087-B

Release date: 27 May 2005.

Safety and Warranty

GENERAL

All cables for the Fleet33 system are shielded and should not be affected by magnetic fields. However, if possible do not run cables parallel to AC wiring – failing to do so might cause the equipment to be faulty or working properly.

SERVICE

User access to the interior of the Transceiver Unit is prohibited. Only technicians authorised by Thrane & Thrane A/S may service the unit - failing to do so will void the warranty. Access to the interior of the Antenna Unit is allowed, but only for replacement of certain modules - as described in this manual. General service on the unit may only be performed by a technician authorised by Thrane & Thrane A/S - failing to do so may void the warranty.

RADAR SAFETY DISTANCE

Do not move the antenna closer to radars than the minimum safety distance specified in this manual - this will possibly damage the antenna eventually.

Equipment must be installed with a minimum safe distance to magnetic steering compass of at least 1.1 m. Personal safe distance is 1.3 m from the antenna while it is transmitting.

GROUNDING, CABLES AND CONNECTIONS

The Transceiver Unit must be grounded at its grounding stud.

The shielded cables must generally be grounded in both ends, except for the cable between transceiver and Cradle, which shall not be grounded in the Cradle end. Connections of all types of equipment must be done while the unit is switched off.

Do not extend the cables beyond those specified for the equipment – except the cable between the transceiver Unit and the antenna unit. This can be extended if it complies with the specified data concerning cable losses etc.

POWER SUPPLY

The operation voltage is 24 VDC. Note that long-term operation below 24 VDC should be avoided.

It is recommended supply to provide supply from the ship hot 24 VDC power bus.

Be aware of high start-up peak current. 11A@24V, 15ms.

Maximum operational peak power requirement for F33 is 110 W and maximum average power consumption is 60 W.

If a 24 VDC power bus is not available, an external 115/230 VAC to 24 VDC power supply can be used.

EQUIPMENT VENTILATION

To ensure adequate cooling of the transceiver a 5 cm unobstructed space must be maintained around all sides of the unit (except the bottom side).

Transceiver Unit ambient temperature range: -25 to +55°C.

Failure to comply with the rules listed above will void the warranty!

INSTALLATION CHECKLIST

#	Subject	Sec.	Check
1	Antenna Site Free of Obstructions	3.2.1	
2	Antenna Site Free of Interference	3.2.2	
3	Selected RF Cable within Limits	3.3.1	
4	Antenna Mast within Specs.	3.3.2	
5	Antenna Properly Grounded	3.3.4	
6	Transceiver Unit Properly Placed	4.1	
7	Check of Ship Source Impedance	4.2.1	
8	Selected DC Cable within Limits	4.2.2	
9	Transceiver Unit Properly Grounded	4.2.3	
10	Handset/Cradle Properly Placed	5.1.1	
11	Handset Cradle Properly Assembled	5.1.2	
12	System Set-up Done	6.3	

Blank page

Table of Contents

1	About the Manual	1
2	TT-3088A System Units.....	3
	2.1 TT-3008G Antenna Unit	3
	2.2 TT-3038G Transceiver Unit.....	4
	2.3 TT-3622E Handset Cradle	4
	2.4 TT-3620G Control Handset.....	5
	2.5 TT-683088A Accessories Kit	5
3	Antenna Unit	7
	3.1 Radiation Hazard	7
	3.2 Antenna Site	8
	3.2.1 Obstructions	8
	3.2.2 Interference.....	8
	3.3 Unit Installation.....	10
	3.3.1 Antenna Coaxial Cable.....	10
	3.3.2 Antenna Unit Mast Design.....	11
	3.3.3 Antenna Unit Mounting.....	12
	3.3.4 Grounding	13
4	Transceiver Unit.....	15
	4.1 Unit Installation.....	15
	4.2 Connecting Power	15
	4.2.1 Ship Source Impedance.....	16
	4.2.2 Power Cable Selection	16
	4.2.3 Grounding	18
5	Cradle/Handset Units.....	19
	5.1 Handset Cradle Unit	19
	5.1.1 Unit Installation.....	19
	5.1.2 Handset Cradle Assembly	20
	5.2 Control Handset Unit	21
	5.2.1 Unit Installation.....	21

Table of Contents

- 6 Setting Up the System23
 - 6.1 Powering Up the System23
 - 6.2 Shutting Down the System.....24
 - 6.3 Service User Menu24
 - 6.3.1 LES Config.....26
 - 6.3.1.1 "Allowed LES" selection26
 - 6.3.2 Help Desk27
 - 6.3.2.1 Inserting a new entry27
 - 6.3.2.2 Deleting an entry28
 - 6.3.2.3 Editing an entry28
 - 6.3.3 IMN Config29
 - 6.3.4 PIN Codes31
 - 6.3.4.1 Changing the Super User Pin31
 - 6.3.4.2 Changing the Service User PIN.....32
 - 6.3.4.3 Unblocking a Super User PIN32
 - 6.3.5 Dflt. Setting.....33
 - 6.3.6 Calibration.....33
- 7 Service and Repair37
- 8 Trouble Shooting.....39
 - 8.1 Error messages39
 - 8.2 "Handset Com Error" - troubleshooting procedure .40
- Appendix A Part Numbers.....43
- Appendix B HW Interfaces45
 - Appendix B.1 Analogue 2-wire46
 - Appendix B.2 Cradle/Handset47
 - Appendix B.3 LAN48
 - Appendix B.4 RS-232.....49
 - Appendix B.5 Discrete I/O50
- Appendix C Technical Spec.51
 - Appendix C.1 TT-3008G51
 - Appendix C.2 TT-3038G55
 - Appendix C.3 TT-3622E59
 - Appendix C.4 TT-3620G61

1 About the Manual

This manual has the following chapters:

Chapter **2 TT-3088A System Units** – an overview of the components in the system.

Chapter **3 Antenna Unit** – a list of guidelines of how to select a proper antenna site and how to install the antenna unit.

Chapter **4 Transceiver Unit** describes how to install the transceiver unit and how to connect power to the system.

Chapter **5 Cradle/Handset Units** lines out how to assemble and install the Handset Cradle and the Control Handset.

Chapter **6 Setting Up the System** runs through the different basic settings of the system.

Chapter **7 Service and Repair** – an overview of the service and repair facilities on the system

Chapter **8 Trouble Shooting** refer to this is trouble occurs.

Appendix A – System Part List and Options

Appendix B – Description of the different interfaces

Appendix C – Technical Specification of the various units.

Blank page

2 TT-3088A System Units



2

The basic system consists of four units: The TT-3008G Antenna Unit (Above Deck Unit - ADU), the TT-3038G Transceiver Unit (Below Deck Unit - BDU), the TT-3622E Handset Cradle and the TT-3620G Control Handset. Furthermore an accessories kit is delivered with the system.

2.1 TT-3008G Antenna Unit

The antenna unit consists of a stabilised antenna with RF-unit and an antenna control unit (ACU) with internal GPS. All communication between the antenna unit and the

transceiver unit goes through a single coaxial cable. The antenna unit is protected by a fibreglass radome.

**2**

2.2 TT-3038G Transceiver Unit

The transceiver unit – which contains the primary electronic parts – is designed for wall or desktop installation. The transceiver unit supplies 28 VDC to the antenna unit through a single coaxial cable. The operational power requirement is 105 W peak and 60 W average at 24 VDC. The power shall be provided by the ship hot 24 VDC power bus, or by an external VAC to VDC power supply (minimum 4.5A). Be aware of high start-up peak current. 11A@24V, @15ms.

2.3 TT-3622E Handset Cradle

The Handset Cradle includes a loudspeaker and holds the Control Handset.

2.4 TT-3620G Control Handset

The Control Handset allows dialling and control of the Transceiver Unit and the Antenna Unit.

2.5 TT-683088A Accessories Kit

The system is delivered with an accessories kit holding the following items:

2

Item	Qty	Name
1	1	Installation Manual (this manual)
2	1	User Manual
3	1	Configuration CD-ROM
4	1	10m Handset Cradle Cable
5	2	Transceiver Unit Mounting Bracket
6	1	7-pole connector for X12
7	1	4-pole connector for X13
8	1	Power Cable for TT3038C/G
9	1	Antenna RF Grounding Strap

2

Blank page

3 Antenna Unit

3.1 Radiation Hazard

The F33 antenna radiates 21 dBW (max.) with a gain of 14 dBi. This translates to a minimum safety distance of 1.3 m from the antenna while it is transmitting. This is based on a radiation level of 0.8 mW/cm².

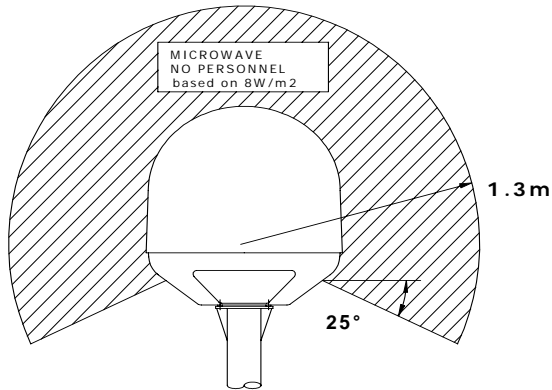

3.2 Antenna Site

3.2.1 Obstructions

The antenna unit rotates 360° and down to -25° in pitch and roll to allow for continuous pointing even during the worst sea states. Any obstructions within this volume can cause signal degradation.

The amount of degradation depends on the size of the obstruction and the distance from the antenna. As a rule of thumb any obstruction, which subtends an angle of less than 3° at the antenna will have limited effect. The table below gives a guideline for obstruction sizes, which will cause limited degradation.

Distance to Obstruction	Size of Obstruction
3 m	16 cm
5 m	26 cm
10 m	52 cm
20 m	105 cm

3.2.2 Interference

The antenna unit must be mounted as far away as possible from the ship radar and other high power radio transmitters, as these can severely compromise the system performance.

Radar

It is difficult to give exact guidelines for minimum distance between the radar and the TT-3008G - as radar power, radiation pattern, frequency and pulse length/shape varies widely from radar to radar. Since a radar radiates a fan beam width a horizontal with of a few degrees and a vertical width up to +/-15°, the worst interference can be

avoided by mounting the TT-3008G at a different level – such that the unit is installed min. 15° above or below the radar.

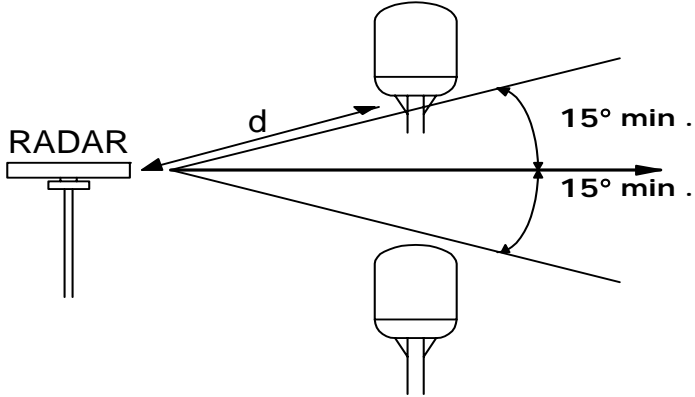

3

The minimum acceptable distance to a radar antenna is determined by the power emitted by the radar. The table below contains some “rule of thumb” distances as a function of the radar power.

Radar power	d min. operational*	d min. damage*
0 – 10 kW	4 m	1 m
30 kW	7 m	2 m
50 kW	12 m	4 m

* When unit is installed outside radar fan beam.

At antenna unit positions more than 60° above or below the radar, it should be possible to reduce “d min. operational”.

It is strongly recommended to verify interference free operation experimentally before the installation is finalised.

Even if experiments show that interference free operation can be obtained at shorter distances than the “d min. operational” given above, the antenna unit must never be installed closer to a radar than the “d min. damage” given above.

Other Inmarsat Systems

Recommended minimum safe distance to other Inmarsat antennas (like Inmarsat B or Inmarsat C) is 10 m.

Other Transmitters

See curves in Appendix C.1 for Minimum Recommended Distance to Transmitters in the frequency range below 1000 MHz.

Other Precautions

Do not place the TT-3008G close to a funnel, as smoke deposits are corrosive. Furthermore, deposits on the radome can degrade performance.

3.3 Unit Installation

3.3.1 Antenna Coaxial Cable

The coaxial cable for connection between the antenna unit and transceiver unit is not part of the basic system. Make sure that a sufficient length of cable is ordered; refer to Appendix A for selected cable options.

The transceiver unit and the antenna unit are connected by a single 50 Ω double screen coaxial cable. The maximum length of the coaxial cable depends on the type of cable used.

The table below shows the specifications for Thrane & Thrane A/S standard cables.

Cable Type	Max. Length
RG223	10 m
RG214	30 m
SA07272	50 m
SA12272	70 m

The coaxial cable can be extended if it complies with the specified losses incl. connection listed below.

- Maximum RF loss, 1525 – 1660 MHz: 10 dB
- Maximum DC loss, R_{loop} : 0.5 Ω

Where exposed to mechanical wear - on deck, through bulkheads, etc. - steel pipes should protect the cables. Standard procedures should otherwise be followed for cabling in ship installations.

3.3.2 Antenna Unit Mast Design

The antenna mast must be designed to carry the 4.5 kg weight of the antenna unit. It must also be able to withstand wind forces up to 140 knots on the radome as well as onboard vibrations.

3

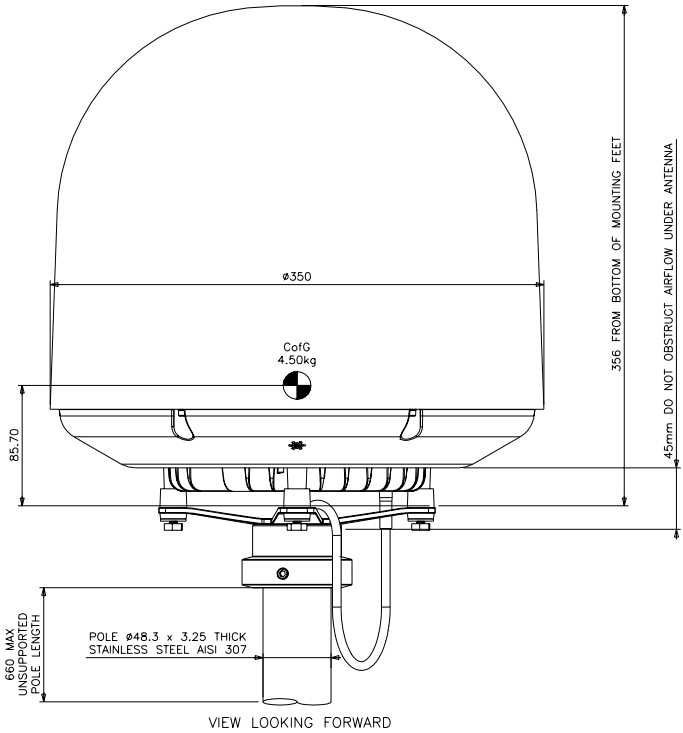

3.3.3 Antenna Unit Mounting

The TT-3008G can now be installed on the mounting pole using the pole mount kit. The only electrical connector is a single TNC-Type connector in the bottom of the antenna.

The antenna tracking system is directional why the heading direction of the antenna unit is extremely important, as setting the wrong heading will cause the antenna to lose track of the satellite as soon the ship start to move. An

arrow placed on the black base defines the F33 heading. This must point in the ships forward direction.

After having connected the antenna cable to the unit – ensure that the connector assembly is properly protected against seawater and corrosion. As a minimum, the use of self-amalgamating rubber tape is recommended.

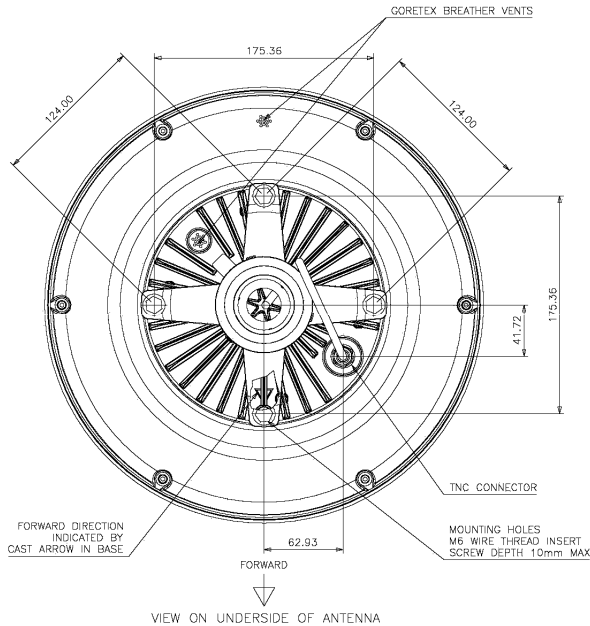

3

3.3.4 Grounding

The TT-3008G should be grounded to ship hull using the grounding strap (item 9).

3

Blank page

4 Transceiver Unit

4.1 Unit Installation

To ensure adequate cooling of the transceiver unit a 5 cm unobstructed space must be maintained around all sides of the unit (except the bottom side).

The unit is manufactured as a cabinet for bulkhead or desktop installation. The cabinet is equipped with two mounting brackets, which makes it possible to secure the unit on a bulkhead, cf. Appendix C.2 "Outline Dimensions".



4

NOTE: It is very important that the unit is placed in an area where access to the hull or equivalent grounding can be reached within 0.5 m.

The TT-3038G must be placed with a minimum safe distance of at least 0.1 m to magnetic steering compass.

4.2 Connecting Power

The length of the Transceiver Unit power cable depends on the type of cable used and the source impedance of the ship 24 VDC supply.

4.2.1 Ship Source Impedance

It is required that the total source impedance at the Transceiver Unit does not exceed 250 m Ω .

Select a power outlet from the 24 VDC ship supply, and measure the source impedance of the ship installation as described in appendix C.2.

If 50 m Ω ship source impedance is measured, only 200 m Ω is left for power cable loop resistance (250 m Ω - 50 m Ω = 200 m Ω).

If the total source impedance is too high the voltage drop when the terminal turns on, is so large that the terminal turns off again. When it turns off the voltage drop goes down to zero and the terminal turns on again, and therefore the terminal rapidly turns on and off.

The cable inductance should not exceed 5 μ H. If the inductance is too high, the Transceiver Unit Power Supply may start to oscillate. You will hear an oscillating noise from the power supply and the antenna voltage will be insufficient.

4.2.2 Power Cable Selection

In order to make sure that the power cable fits the power connector the dimensions of the cable must be:

- Cable outer diameter max 3 mm
- Inner core 1.5 mm²

To minimize the cable inductance a multi 2- or 4-wire cable should be used.

Recommended power cable types and length from source:

Cable Type	Length from source. (source imp. < 50mΩ)	Length from source. (source imp. < 100mΩ)
2 x 1.5mm ²	0 – 10 m	0 – 7 m
2 x 2 x 1.5mm ²	10 – 20 m	7 – 14 m
Power converter or extra battery	> 20 m	> 14 m

The power connector have the option of running four cables instead of two, which allow the cable to be twice as long.

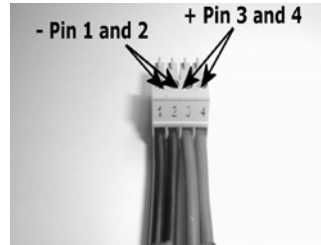
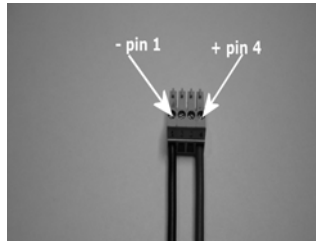

4

Cables with larger cross-section area that 1.5 mm² may be connected to the TT-3038G by use of the pigtail that is supplied with the system.

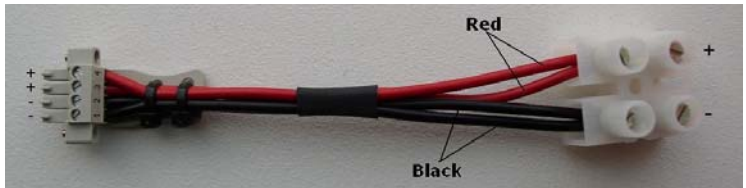

By use of this pigtail, you may extend the cable length as long as you keep the total source impedance < 250 mΩ and cable inductance < 5μH.

The TT-3038G is equipped with an internal 10A thermal circuit breaker; therefore no external fuse is necessary in order to protect the unit. However, in order to avoid short

circuit in the power cable/connector, the ship DC outlet should be protected by a 10 Amp fuse or circuit breaker.

When the TT-3038G is turned off, the voltage measured directly on the transceiver unit power connector, should be in the range 24V DC -10%/+30%, i.e. 21.6V – 31.2V.

As the power cable voltage loss may be significant, it is recommended to check the input voltage of the unit also when transmitting at a high power level. Setting up a 9.6K data connection can insure this. Under these circumstances the voltage measured directly on the transceiver unit power connector should be higher than 18.3 V.

4.2.3 Grounding

The TT-3038G should be grounded to ship hull using the ground bushing on the rear side of the transceiver unit.



5 Cradle/Handset Units



5.1 Handset Cradle Unit

5.1.1 Unit Installation

The Handset Cradle used for F33 can be placed anywhere onboard the ship.

The only limitations are:

- Maximum cable length of 40 m.
- Minimum safe distance to magnetic steering compass 1.1 m.

No special grounding of the Handset Cradle is required.

5.1.2 Handset Cradle Assembly

The Handset Cradle comes with an assembly kit holding the following parts:

Item	Qty	Name
1	4	Screw, Sheet screw 3,5 x 25 A4
2	4	Rubber Blind Plug, 3622A
3	1	Relieving Clamp
4	6	Screw 3 x 10 PT Self tapping
5	2	Screw 3 x 6 PT Self tapping
6	1	Blind Plate

Connect the cable and secure the cable using the relieving clamp (3). A small self-adhesive tape is placed on the PCB to match the cable together with the cable relief clamp. Connect the speaker and insert the blind plate (6).



Assemble the upper and lower cradle part using the self-tapping screws. Mount the cradle at the wall and cover the mounting holes using the four blind plugs (2).

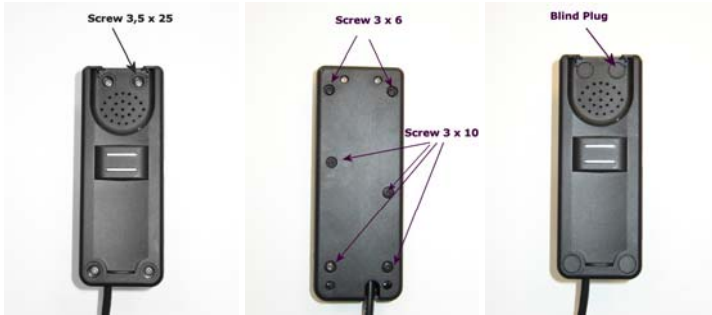

5.2 Control Handset Unit

5.2.1 Unit Installation

The TT-3620G Control Handset is installed by plugging in the RJ45 connector to the TT-3622E Handset Cradle.

After this the Control Handset can be placed in the cradle.

Blank page

6 Setting Up the System

6.1 Powering Up the System

The Sailor F33 can be powered up using either the transceiver unit power button or the handset unit power key, .

The power button on the transceiver unit is placed on the back panel. See figure below.



Press and hold the power button for a few seconds or until the green LED on the front of the terminal, and the handset display, lights up, then release the button.



6.2 Shutting Down the System

Press and hold either power buttons for a few seconds, while the handset display shows the message shown below.



Let go of the button when the display shows the message below, and the green LED on the front of the terminal starts flashing.



Note: Wait at least 10 seconds after a shut down, before trying to power up the F33 system again.

6.3 Service User Menu

Before the system is ready to make the first call – some basic system configuration is necessary. The Service User is the only user having access to all functionality in the system. The Service User must therefore perform all changes to the configuration.

The system configuration can be accessed via the handset or by running the FleetCp program from a PC connected to the transceiver (cf. **User Manual** section 5.1 “System Set-up from PC”).

All configuration information is stored in the configuration module. It takes approx. 10 sec for the system to update

and store configuration information. When configuration information is changed or added wait min. 10 sec before shutting down the system.

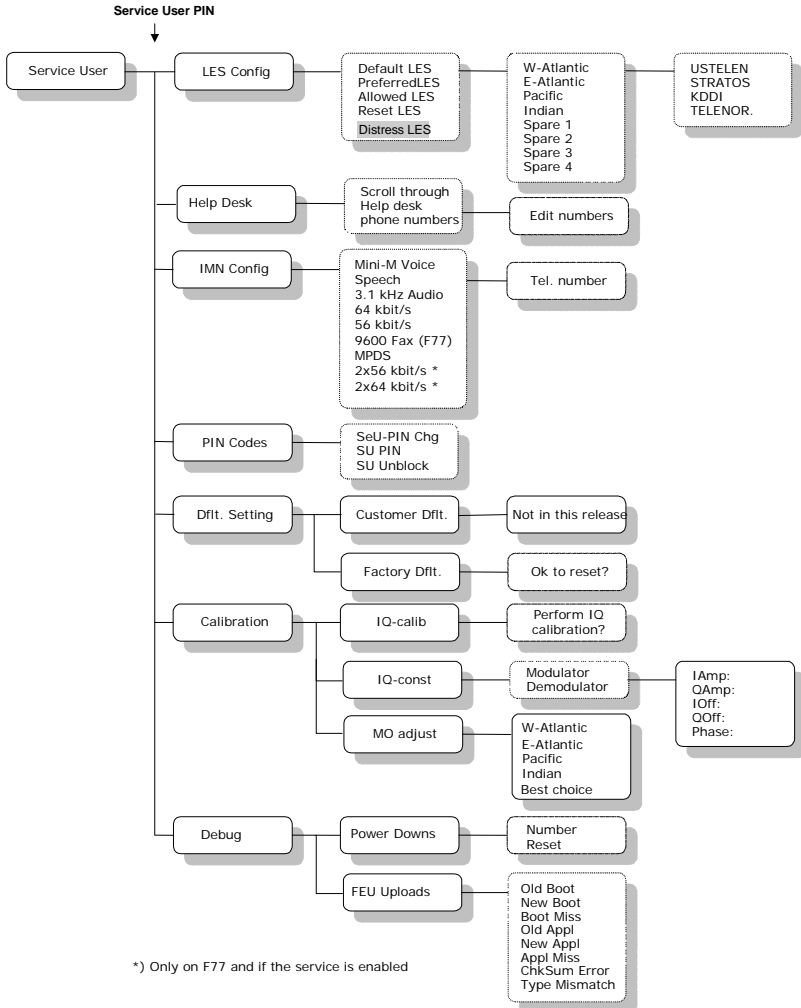

6.3.1 LES Config

This menu is used to select a list of LES operators. It contains the following sub menus:









- Default LES
- Preferred LES
- Allowed LES
- Reset LES

“Allowed LES” is the only menu that is special to the Service User menu. For the description of the other LES configuration sub menus you are referred to the **User Manual**.

6.3.1.1 “Allowed LES” selection

The **Allowed LES** list can be selected under the Service User menu. The Service User/supplier can decide, which LES are allowed to be used in a selected ocean region.

Use  or  to toggling between options.

- Select **Service User** from the main menu and press .
- Type the Service user PIN code and press  to enter the Service user menu.
- Select **LES Config** and press .
- Select **Allowed LES** and press .
- Select ocean region and press .
- A list of all available LES should appear and for each LES intended to be on the list press  .
- Press  to update the **Allowed LES** list.

- To remove a LES from the list, press **[2nd] [F 2nd]** and then **[OK]** to update the list.

The configuration must be done for each Ocean Region.

Only the LES marked in the **Allowed LES** list can be selected as Default or Preferred LES.

If no **Allowed LES** list is made all LES are accessible.

It is then the **Preferred LES** list that decides, which LES that can be used as **Default LES**.

6.3.2 Help Desk

The Help Desk menu can be used to select and initiate calls to certain numbers, which may provide help in case you have forgotten your PIN code.

Editing/inserting and deleting entries can only be done from the service user menu.

Each entry contains a name, phone number of the entry and a LES access code.

6.3.2.1 Inserting a new entry

Use **[Up] [2nd]** or **[Down] [2nd]** to toggling between options.

- Select **Service User** from the main menu and press **[OK]**.
- Type the Service user PIN code and press **[OK]** to enter the Service user menu.
- Select **Help Desk** and press **[OK]**.
A list of entries should now appear.
- To add a new entry press **[2nd] [C^{new}]**.

- Insert the name and press **OK**.
- Insert the number and press **OK**.
- Insert the LES access code and press **OK**.
- To exit service menu and return to ready mode press **Exit** three times.

6.3.2.2 Deleting an entry

There is only room for ten numbers in the Help desk phone book. If there is no more room for new phone numbers, one entry will have to be deleted before a new number can be added.

Use **Enter** or **Down** to toggling between options.

- Select **Service User** from the main menu and press **OK**.
- Type the Service user PIN code and press **OK** to enter the Service user menu.
- Select **Help Desk** and press **OK**.
A list of entries should now appear.
- Select an entry and press **2nd F8** to delete the entry.
- To exit service menu and return to ready mode press **Exit** three times.

6.3.2.3 Editing an entry

Use **Enter** or **Down** to toggling between options.

- Select **Service User** from the main menu and press **OK**.

- Type the Service user PIN code and press **[OK]** to enter the Service user menu.
- Select **Help Desk** and press **[OK]**.
A list of entries should now appear.
- Select an entry and press **[2nd] [↑^{Edit}]** to edit the entry.
- Edit the name and press **[OK]**.
- Edit the number and press **[OK]**.
- Edit the LES access code and press **[OK]**.
- To exit service menu and return to ready mode press **[Exit]** tree times.
- To exit service menu and return to ready mode press **[Exit]** tree times.

6.3.3 IMN Config

Inmarsat Mobile Numbers are assigned to the terminal during service commissioning (done by the Service Provider, ISP). The IMN Configuration menu is subdivided into the services available:

- mini-M voice
- 9.6kbps fax
- 9.6kbps data
- MPDS

In each menu, all IMN's associated with a specific service should be inserted.

Note: The IMN-number has to be defined, before the service can be routed to an interface. The service will not be listed in the routing table, unless it has an IMN defined.

After inserting the IMN number and pressing X the handset will show "ID" and a number. The ISP may also have indicated the corresponding ID along with an IMN-number.

If the ID shown by the terminal corresponds with the ID given by the ISP press X. If not, then press  to correct the ID, type in the correct ID and confirm with X.

If the ISP has not indicated the ID for each IMN number two situations exist:

- 1) If there is not more than one IMN-number pr. service and the IMN list is empty, the ID shown by the terminal will always be correct and thus just press X.
- 2) If there is more than one IMN-number pr. service and the IMN list is empty, the rule is that the first (or upper) IMN on the returned commissioning form will have the lowest ID and each subsequent IMN-number will have an ID which is 1 higher than the predecessor.

Note: In case the IMN's are combined with the wrong ID's, the wrong interface may be activated for incoming calls. Furthermore, reference IMN for a hardware interface when making outgoing will be wrong. Thus service type and billing will be otherwise than expected. The ISP may help you with this.

ID's are entered as decimal and the allowed range pr. service type is as follows:

Service	ID – range
Mini-M Voice	1 – 15
9600 Fax	17 – 31
9600 Data	33 – 47
MPDS	161 – 175

6.3.4 PIN Codes

Access to some of the terminal functionality is restricted by PIN codes. Two kinds of PIN codes exist, Super User and Service User PIN. For both PIN code types the length must be between 4 and 8 digits long and contains digits between 0 and 9.

If the Super user/Service User PIN code is entered incorrectly 5 times, the PIN becomes blocked.

A blocked Super User PIN can be unblocked with a PUK code (Normally known to the Super User) or by a Service User.





The default factory Service User PIN code is '12345678'.

A blocked Service User PIN can be unblocked with a PUK code or by a Service User.

Normally the Service User PUK code is only known by Thrane & Thrane A/S and/or the supplier.

6.3.4.1 Changing the Super User Pin

Use  or  to toggling between options.

- Select **Service User** from the main menu and press .
- Type the Service User PIN code and press  to enter the Service user menu.
- Select **PIN Codes** and press .
- Select **SU PIN** and press .
- Press  to change the PIN.

- Enter new PIN and press **OK**.
- Retype PIN and press **OK**. The display will now show if the PIN was OK saved to memory.

6.3.4.2 Changing the Service User PIN

Use **Enter** or **Back** to toggling between options.

- Select **Service User** from the main menu and press **OK**.
- Type the Service User PIN code and press **OK** to enter the Service user menu.
- Select **Pin Codes** and press **OK**.
- Select **SeU-PIN Chg** and press **OK**.
- Press **OK** to change the PIN.
- Enter new PIN and press **OK**.
- Retype Pin and press **OK**. The display will now show if the PIN was OK saved to memory.

6.3.4.3 Unblocking a Super User PIN





Use **Enter** or **Back** to toggling between options.

- Select **Service User** from the main menu and press **OK**.
- Type the Service User PIN code and press **OK** to enter the Service user menu.
- Select **PIN Codes** and press **OK**.
- Select **SU-Unblock** and press **OK**.

6.3.5 Dflt. Setting

The Sailor F33 offers the possibility of changing the system configuration to Factory Default Setting. Please note the current configuration will be lost.





Use  or  to toggling between options.

- Select **Service User** from the main menu and press .
- Type the Service User PIN code and press  to enter the Service user menu.
- Select **Dflt. Setting** and press .
- Select **Factory Dflt.** and press .
- Press  to confirm that you want to return to Factory Default Setting.

6.3.6 Calibration

Normally the system is factory calibrated, but in some situations like service or repair additional calibration might be needed.

Use  or  to toggling between options.

- Select **Service User** from the main menu and press .
- Type the Service User PIN code and press  to enter the Service user menu.
- From the Service User menu select **Calibration** and press .
- Select either **IQ-calib**, **IQ-const** or **MO adjust** and press .

Below each submenu is described:

IQ-calib

This selection will perform an IQ-calibration. When activated, calibration might run for about 10 minutes.

While calibrating, the handset display will show "Calibrating Wait..." and when finished the display shows "Done" and the terminal will reset itself.

If calibration fails the display shows "Failed Try Again" for 20 seconds or until you press any key.

IQ-const:

This selection is used to read the IQ constants for Modulator and Demodulator. The IQ-constant order is: Iamp, Qamp, Ioff, Qoff, Phase.

MO adjust:

This selection will adjust the system Master Oscillator (MO). Normally the MO adjustment is maintained during normal use of the terminal. Under special conditions, e.g. system not used for a very long time, the MO long-term drift will prevent satellite synchronisation. This will be revealed by an error message after power-up showing "Wait for NCS".

This selection will readjust the MO. Fine-tuning will take place automatically during subsequent normal use.

When adjustment is started the following list is shown:

- W-Atlantic
- E-Atlantic
- Pacific
- Indian
- Best Coice

Choose the satellite you think has the best signal in the present conditions. If you choose "Best choice" the satellite will be selected on the basis of the GPS position reported from the antenna.

When a satellite has been chosen, the adjustment procedure will start. This adjustment may be very long (hours) as both master oscillator frequency as well as antenna direction is scanned. At the end the display will show whether or not the adjustment was successful. If the adjustment was unsuccessful no changes will be made to the MO.

Blank page

7 Service and Repair

The Thrane & Thrane Fleet systems are designed to operate without preventive routine maintenance.

Although the system is designed and built very service friendly, we strongly recommend that any acting service technician have been trained specifically on the product. Repairs or repair attempts performed by unqualified personnel may limit the warranty.

The warranty on the system is defined and outlined by the Distributor that supplied the system.

For further information on warranty and service, you may also use the Thrane and Thrane home page at <http://www.thrane.com> .

Repairs inside the transceiver or antenna unit is not recommended to be carried out on board, instead units should be replaced, if defective and repaired at a qualified workshop on shore.

Blank page

8 Trouble Shooting

If the antenna unit should fail an error message will be sent to the Alarm log (cf. **User Manual** sections 4.1.6 “Alarm Log” and 2.4 “The Control Handset”).

8.1 Error messages

An error message does not pinpoint the exact location of the unit, which is causing the fault – but it gives an idea of where to start troubleshooting. An error message can be hardware or software related.

If an error message is received - start the trouble shooting by restarting the system.

Error Message	Possible Reasons	Actions
FEU Status <u>Heat alarm</u>	a) System error or b) Temperature inside radome exceeds 90°C or c) Cooler fan failure or d) HPA failure	Restart the system
FEU Status <u>Burst alarm</u>	a) System error or b) HPA failure	Restart the system
FEU Status <u>Power alarm</u>	a) System error or b) HPA failure	Restart the system
Antenna <u>Link down</u>	a) System error or b) Antenna cable disconnected/faulty or c) Antenna unit failure	1) Check cable and restart the system otherwise 2) Return the unit for repair

Error Message	Possible Reasons	Actions
Motor Error <u>Azm drive</u> Motor Error <u>Azm wind</u> Motor Error <u>Elv drive</u> Motor Error <u>Elv wind</u>	a) System Error b) ACU module faulty c) Azimuth motor faulty d) Elevation motor faulty	1) Restart the system or 2) Replace ACU module or 3) Return the unit for repair
Handset Com Error	No communication between Transceiver and Handset caused by e.g.: <ul style="list-style-type: none"> • Handset/cradle cable error • BDE error • ADE error 	As this error indicates an error that may be caused by many different reasons, there is an elaborate troubleshooting procedure to follow (cf. below)

If other error messages than those shown in the table are received – contact supplier or Thrane & Thrane for Support.

8.2 “Handset Com Error” - troubleshooting procedure

Step 1: Check alarm log

Check for any active/recent alarms. E.g. low voltage may cause the error and therefore look for any low voltage alarms.

Step 2: Below Deck Equipment (Transceiver, Handset, Cradle) or Above Deck Equipment (Antenna) error?

- Remove power
- Disconnect antenna cable
- Reinstall power
- Switch on system (disregard "Antenna link down" error")

Does "Handset Com error" still appear? If yes, it is a below deck error. If no, it is an above deck error.

Step 3a (if Below Deck Equipment error):

- Check/replace Handset
- Check/replace Cradle
- If these replacements do not remove the error return defective transceiver for repair

Step 3b (if Above Deck Equipment error):

- Switch system off.
- Connect the antenna cable.
- Switch system on.
- In antenna:
 - Check the DSP LED (flash). If no, check 28V to antenna.
 - Check BITE Error LED (off). If no, replace ACU.
 - Check the RX LED (flash). If no, check com. cables.

Blank page

Appendix A Part Numbers

TT-3088A Sailor Fleet33

Sailor Fleet33 Antenna (ADU)	TT-3008G
Sailor Fleet33 Transceiver Unit (BDU)	TT-3038G
Sailor Fleet33 Handset Cradle	TT-3622E
Sailor Fleet33 Control Handset (4 wire)	TT-3620G

Sailor Fleet33 Antenna Cables

10 meter cable, RG223, TNC/TNC	TT37-403064-942
20 meter cable, RG214, TNC/TNC	TT37-403064-944
30 meter cable, SA07272, TNC/TNC	TT37-403064-945
50 meter cable, SA12272, TNC/TNC	TT37-403064-947

Note: Antenne cable not included in the acc. package.

Sailor Fleet33 Accessories

Sailor Fleet33 Power Connector ^{*)}	TT31-202329-104
Sailor Fleet33 I/O Connector ^{*)}	TT31-202329-107
Sailor Fleet33 User Manual ^{*)}	TT98-116874
Sailor Fleet33 Installation Manual ^{*)}	TT98-120087
Sailor Fleet33 CDROM (incl. FleetCp) ^{*)}	TT83-120449
Sailor Fleet33 Mast Mount Kit	TT683088A-920

^{*)} Included in the TT-3088A accessories package.

Optional Sailor Fleet33 Cradle Cables

10 m cradle cable ^{*)}	TT683088A-952
25 m cradle cable	TT683088A-954
40 m cradle cable	TT683088A-955

^{*)} Included in the TT-3088A accessories package.

Sailor Fleet33 Spare Part Units

Sailor Fleet33 Antenna Unit	S-403008G
Sailor Fleet33 Transceiver Unit	S-403038G
Sailor Fleet33 Handset Cradle	S-403622E
Sailor Fleet33 Control Handset	S-403620G
Sailor Fleet33 Accessories Kit	S-683088A
Sailor Fleet33 Mast Mount Kit	S-683088A-920



Appendix B HW Interfaces

All hardware interfaces are found at the rear of the TT-3038G. These interfaces can be used for the Inmarsat Fleet services.



The Transceiver Unit has the following additional hardware interfaces:

- Analogue 2-wire (phone/fax) RJ11 number 1 (X1)
- Analogue 2-wire (phone/fax) RJ11 number 2 (X2)
- Handset/Cradle (X4)
- Antenna (X6)
- Ethernet (X9)
- RS-232 (X10)
- 4 Discreet I/O (X12) (For future use)
- Power input (X13)

Appendix B.1 Analogue 2-wire



The transceiver has two RJ11 ports, which can be used for connection of analogue phone or fax.

The connector outline and pin assignments are described in the figure and table below.

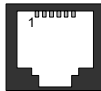

Pin Number	Pin Function
1	-
2	-
3	2-Wire (tip)
4	2-Wire (ring)
5	-
6	-

Max cable length from unit to phone/fax is 200 meter.

Appendix B.2 Cradle/Handset



The transceiver has one 4-wire Cradle/Handset ports with RS-485 data control. The handset can be used to setup the terminal and also can be used to make or receive phone calls. The connector outline and pin assignments are described in the figure and table below.

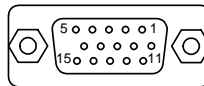

Pin Number	Pin Function
1	Audio Out Hi
2	Audio Out Lo
3	Audio In Hi
4	Audio In Lo
5	+28VDC
6	GND
7	SDA
8	SDB
9, 10, 11, 12, 13, 14, 15	-
Shield	GND

Maximum cable length unit to Handset/Cradle is 40 meter.

Appendix B.3 LAN



The transceiver has one 10baseT Ethernet port for LAN use.

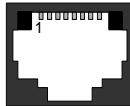

Pin number	Pin Function
1	TxP
2	TxN
3	Rxp
4	-
5	-
6	RxN
7	-
8	-

Appendix B.4 RS-232



The transceiver has one RS-232 port. The RS-232 port is a standard 9 - pin serial ports with a maximum port speed of 115.2 kbps. It can be used for the following applications:

- 9.6k Data Service or MPDS Service
- Configuration of the terminal via Fleet CP software

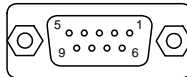

Pin Number	Name	Signal
1	DCD	Data Carrier Detect
2	RxD	Received Data
3	TxD	Transmitted Data
4	DTR	Data Terminal Ready
5	GND	Ground
6	DSR	Data Set Ready
7	RTS	Request To Send
8	CTS	Clear To Send
9	RI	Ring Indicator

Appendix B.5 Discrete I/O



The transceiver also has a discrete I/O interface containing four input/outputs, of the open collector type. Inputs may be used for outputs for external alarms, debit pulses, B-Answer, payphone interface etc. The connector outline and pin assignments are described in the table below.

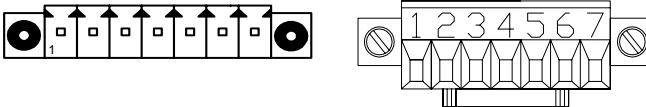

Pin Number	Connection	Note
1	GND	This group signals refer to BDU/ship ground
2	+28 VDC/50 mA Out	
3	Common Return	This group of signals are isolated from all other signals.
4	Discrete I/O D	
5	Discrete I/O C	
6	Discrete I/O B	Can be used together with pin 1 and 2 or ship battery (but not at the same time)
7	Discrete I/O A	

Appendix C Technical Spec.

Appendix C.1 TT-3008G

TT-3008G - GENERAL SPECIFICATION	
Rx Freq. Band	1525.0 – 1559.0 MHz
TX Freq. Band	1626.5 – 1660.5 MHz
Channel Spacing	1.25 kHz
Antenna element	Gain (RX-band, min): 13.5 dBi Gain (TX-band, typical): 14.0 dBi
G/T	G/T \geq -12.5 dBK
EIRP	Min. EIRP: 5 dBW Max. EIRP: 21 dBW
Return loss	Better than -12 dB/50 Ω
Cable losses	RF attenuation: max. 10 dB DC resistance: max. 0.5 Ω <u>Max. Cable length between BDU and ADU:</u> RG223: 10 meter RG214: 30 meter SA 07272: 50 meter SA 12272: 70 meter
Input Voltage	28 V
Antenna Power range, operational	10 W – 108 W
Moment at base interface	

TT-3008G - Environmental Specification	
Degree of protection	IP66 according IEC-529
Ambient Temperature	Operational: -25° to 55° C Storage: -40° to 80° C
Vibration	Frequency range: 3-100 Hz Acceleration spectral: 3-13 Hz, +12 dB/octave Density: 13-100 Hz, 0.011 g ² /Hz Total RMS level: 1.0 g
Icing	Up to 25mm of ice.
Wind	Normal operation with relative average wind velocity up to 140 knots
Ship motions:	Roll: +30°, period 8 sec., 0.5 g tan. Pitch: +10°, period 6 sec., 0.5 g tan. Yaw: +8°, period 50 sec. Surge: +0.2 g Sway: +0.2 g Heave: +0.5 g Turning rate: +/- 6 deg/s; 1 deg/s ² Headway: 30 knots
Dimensions (H x D)	345 mm x Ø350mm
Weight	4.5 kg

TT-3008G – Outline Dimension [mm]

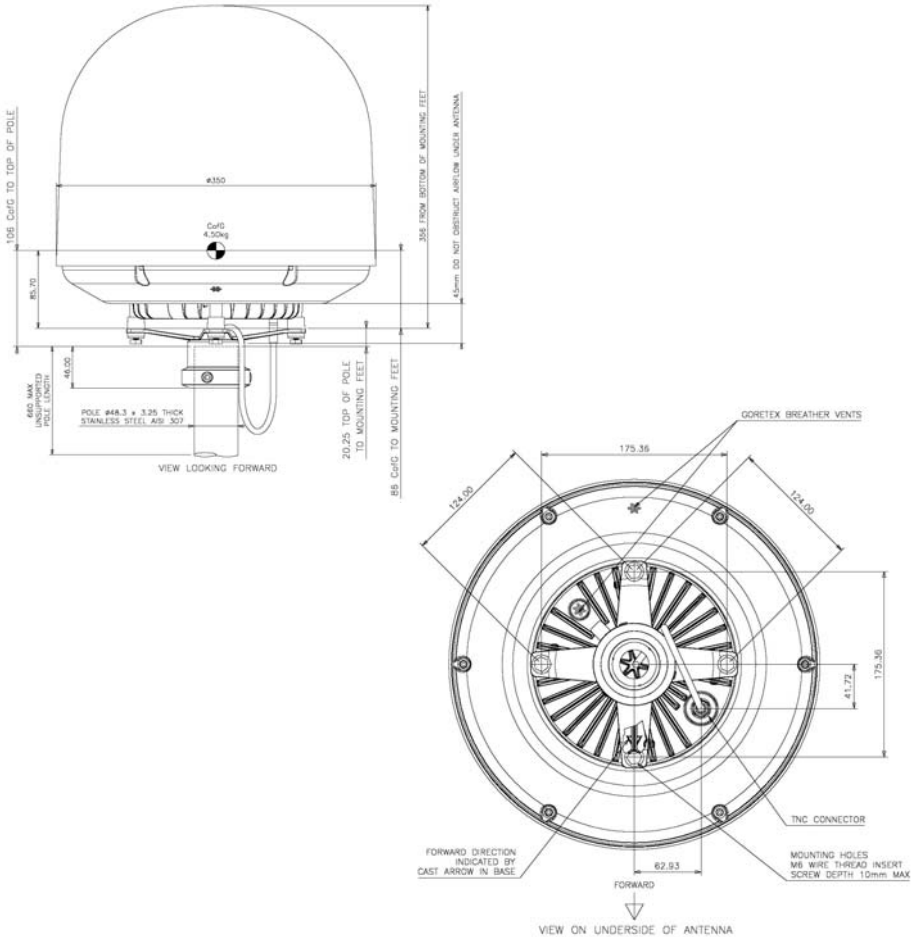

TT-3008G – Minimum Recommended Distance to Transmitters

Frequency range below 1000 MHz

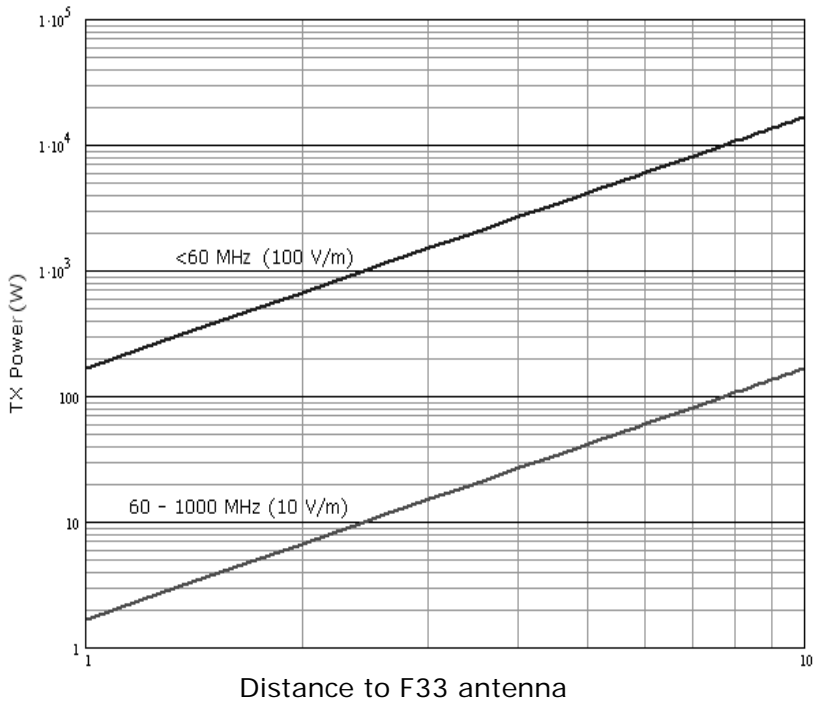

Appendix C.2 TT-3038G

TT-3038G - GENERAL SPECIFICATION	
Channel modulation	RX: 5.6 kbps O-QPSK, SCPC (voice) 6 kbps BPSK, TDM 134.4 kbps 16QAM, (MPDS) 24 kbps O-QPSK, SCPC (fax/data) TX: 5.6 kbps O-QPSK, SCPC (voice) 3 kbps BPSK, TDMA 28 kbps $\pi/4$ -QPSK (MPDS) 24 kbps O-QPSK, SCPC (fax/data)
Antenna Connector	TNC-female
Antenna Voltage	+28V
2-wire telephone interface; X1, X2	600 Ω ITU-T Rec. G. 473, standard DTMF telephone, RJ-11 modular jack. Supported cable length: up to 200 meters
4-wire Handset; X4	Analogue 4-wire interface with RS-485 data. <i>Nominal supply:</i> 28V DC, 3.5W <i>Supported cable length:</i> up to 40 meters <i>Connector:</i> DB9 High Density female
LAN; X9	Ethernet: 10baseT
Data Terminal Interface or Message Terminal; X10	Serial EIA standard RS-232 E, Hayes compatible. <i>Maximum Cable Length:</i> 15m (max. 2.5 nF cable capacity). <i>Data Rate:</i> up to 115 kbps. <i>Connector:</i> DB9 female.
Power Input; X13	Nominal 24VDC (-10%/+30%), 4.5A

TT-3038G - Environmental Specification	
Degree of protection	IP52 according IEC-529
Ambient Temperature	Operational: -25° to 55° C Storage: -40° to 80° C
Relative Humidity	95% non-condensing at 40° C
Vibration	Frequency range: 3-100 Hz Acceleration spectral: 3-13 Hz, +12 dB/octave Density: 13-100 Hz, 0.011 g ² /Hz Total RMS level: 1.0 g
Dimensions (H x W x D)	50 mm x 377 mm x 130 mm
Weight	1.9 kg

TT-3038G – Outline Dimension [mm]

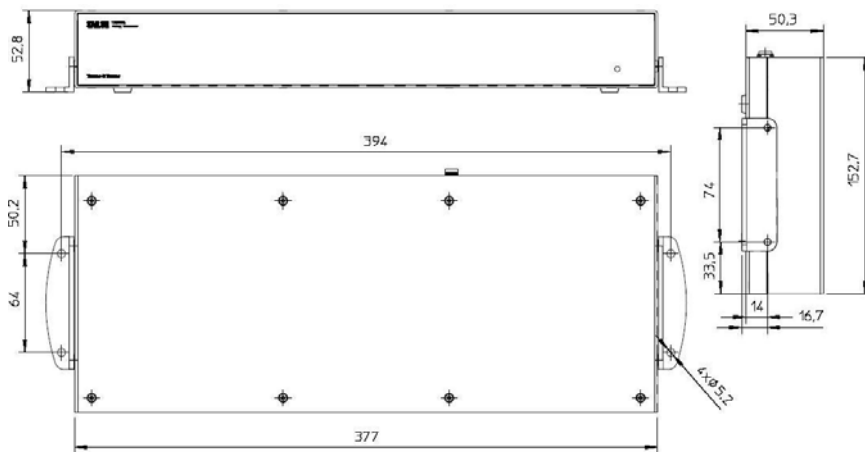

TT-3038G – Measuring the Ship Source Impedance

Select a power outlet from the ship 24 VDC system, and measure the source impedance of the ship installation as described below.

Measure the voltage without load (R.var disconnected).

Set the current to e.g. 1 Amp by adjusting R.var - and measure the corresponding voltage change.

Example:

1 Amp and 50 mV. Source impedance: $50 \text{ mV} / 1 \text{ Amp} = 50 \text{ m}\Omega$.

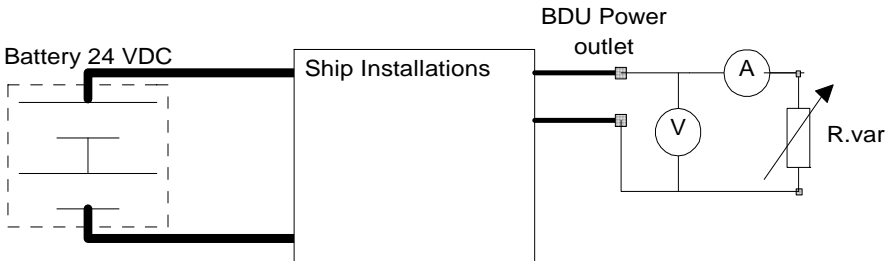

Appendix C.3 TT-3622E

TT-3622E – General Specifications	
Interface to transceiver	Connector type: DB9HD male Connector type: M80-8881005 (female on cable), M80-8671022 (male to PCB) Audio RX, 2 wire balanced, 600 Ohm Audio TX, 2 wire balanced, 600 Ohm Max. 40m Cable
Interface to Handset	Connector type: RJ45 10-pole female
Power consumption	Max. 75mA @ 28V supply voltage
Compass safety distance	125 cm.

TT-3622E – Environmental Specifications	
Degree of protection	IP40 according IEC-529
Ambient temperature:	Operational: -15° to 55° C Storage: -40° to 80° C
Relative Humidity	95% non-condensing at 40° C
Vibration	Frequency range: 3-100 Hz Acceleration spectral: 3-13 Hz, +12 dB/octave Density: 13-100 Hz, 0.011 g ² /Hz Total RMS level: 1.0 g
Dimensions (H x W x D)	160.5 mm x 61 mm x 28mm
Weight	0.18 kg excl. cable

TT-3622E – Outline Dimension [mm]

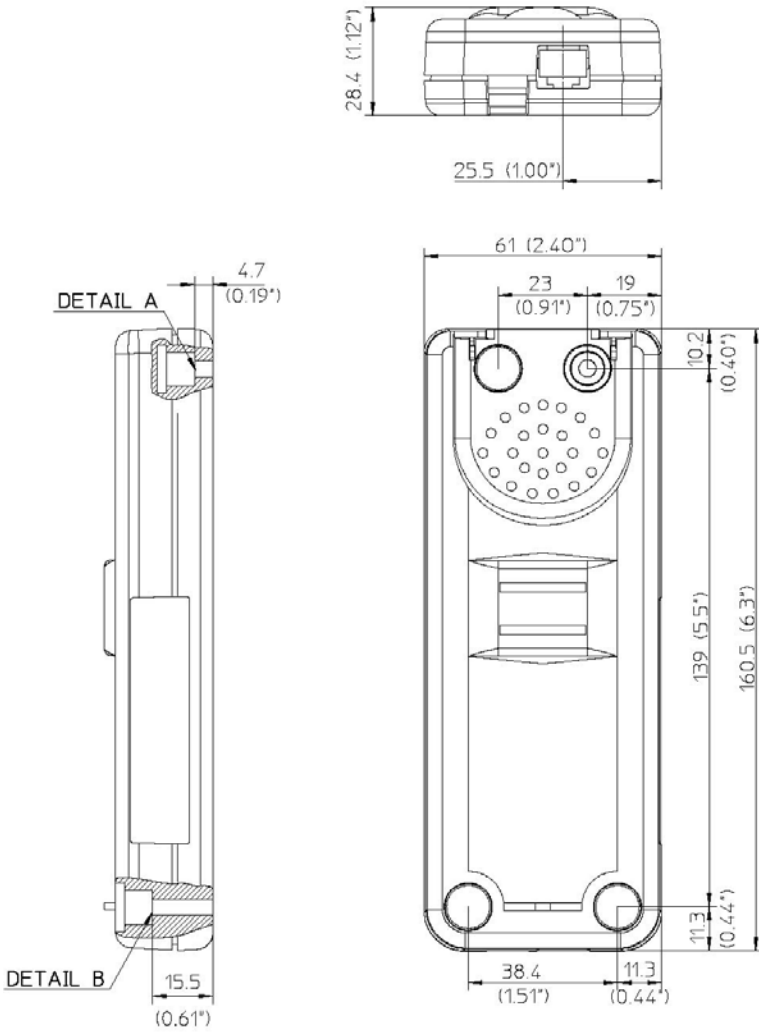

Appendix C.4 TT-3620G

TT-3620G – General Specifications	
Display	2 *12 Alpha, plus additional symbols. Background light.
Keypad	4 * 3 Numeric Keypad 3 * 3 Function Keypad
Volume Control	Att.range > 20 dB
Power consumption	100 mA @ 5 V supply voltage
Compass safety distance	125 cm
Interface	Connector type: RJ45 10-pole

TT-3620G – Environmental Specifications	
Degree of protection	IP40 according IEC-529
Ambient temperature:	Operational: -15° to 55° C Storage: -40° to 80° C
Relative Humidity	95% non-condensing at +40° C
Vibration	Frequency range: 3-100 Hz Acceleration spectral: 3-13 Hz, +12 dB/octave Density: 13-100 Hz, 0.011 g ² /Hz Total RMS level: 1.0 g
Dimensions (H x W x D)	200 x 52 x 33 mm
Weight	0.24 kg

TT-3620G – Outline Dimension [mm]

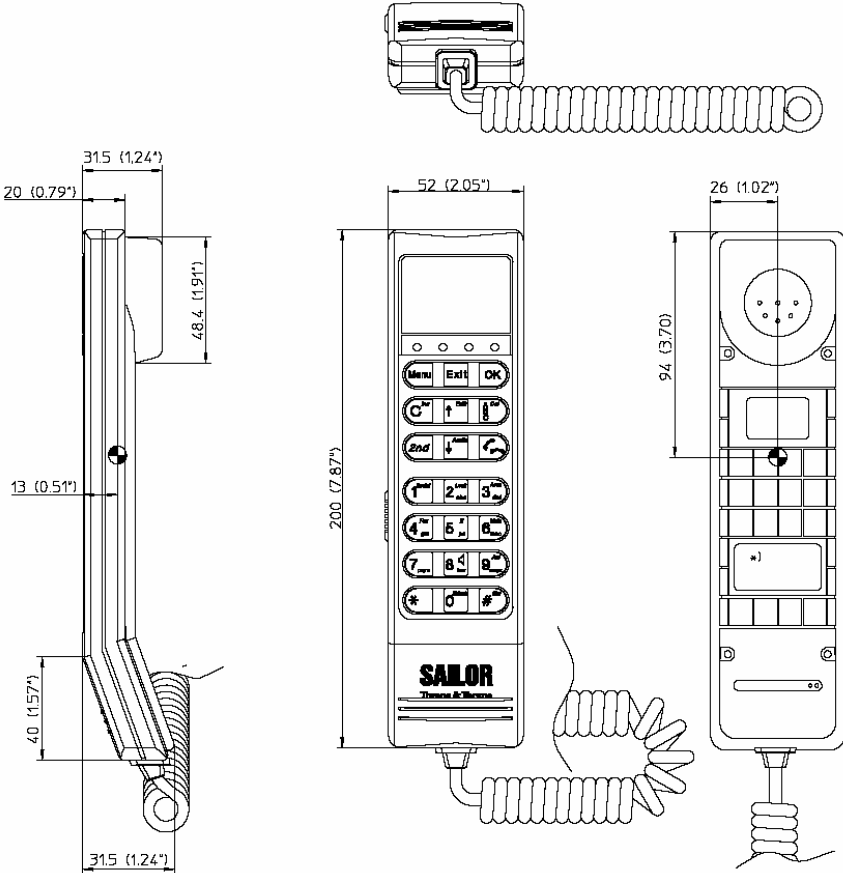



KVH Industries, Inc.

50 Enterprise Center • Middletown, RI 02842-5279 • U.S.A.
Phone: +1 401 847-3327 • Fax: +1 401 849-0045
E-mail: info@kvh.com Internet: www.kvh.com

KVH Europe A/S

Kokkedal Industripark 2B 2980 Kokkedal Denmark
Phone: +45 45 160 180 Fax: +45 45 160 181
E-mail: info@kvh.dk Internet: www.kvh.com