



POCKET-SIZED BROADBAND SATELLITE COMMUNICATIONS



Pocket-Sized Broadband Satellite Communications

Inmarsat's BGAN service signals a new era for mobile satellite communications. The world's first mobile broadband service over satellite, BGAN delivers bandwidth equivalent to terrestrial DSL services. Building on the Inmarsat satellite network's unmatched coverage and reliability, BGAN is designed to provide highly demanding users with broadband communications anywhere on the globe.

Nera has designed a terminal for the typical BGAN user who is constantly on the move and often works from remote locations without access to technical support. Despite being the world's smallest and lightest broadband satellite terminal, the Nera World-Pro 1000 still delivers the power of BGAN.

A New Era For Satellite Communications

For more than 25 years, Inmarsat mobile satellite services have been the only reliable communications alternative for professionals working in the most inaccessible and undeveloped corners of the world. The network's coverage and service quality are widely considered as superior to other satellite communications services. Moreover, operating in the L-band of the radio frequency spectrum, the Inmarsat network can deliver services via battery-operated terminals considerably smaller than the terminals and antennas employed for Ku-band or Ka-band satellite services.

With data communications' increasing importance in many fields, Inmarsat decided to extend its services to meet the 21st century's demands for bandwidth, coverage and reliability. The result is BGAN – Broadband Global Area Network – the world's first mobile broadband satellite communications service. Delivered over a new generation of satellites, BGAN services use enhanced RF properties and more than 200 narrow spot beams.

BGAN enables professionals operating in the field to use the same data applications they rely upon in an office environment. This has enormous potential for roaming field workers in areas without communications infrastructure.

For the BGAN service to function optimally in the field, a compact, lightweight and powerful communications terminal is needed. It should be a quarter of the size and half the weight of the previous terminals, yet deliver six times the performance.

Nera has met this R&D challenge with the Nera WorldPro 1000 – and clearly demonstrated its ability to tailor solutions for the most demanding of users.



Broadband data communications on the move.

Pocket-Sized Terminal

Professionals on the move, – whether military personnel, aid workers or journalists – rely on compact, lightweight equipment to carry out their work. Moving into remote locations at short notice, changing vehicles frequently and working whenever the possibility arises, they need a ‘mobile office’ that is always on hand and rapid to set up.

Compact one-patch antenna

A one-patch antenna is a critical starting point for designing a small satellite terminal, minimising the space taken up by the antenna components. Yet Nera’s engineers were still faced with numerous challenges in order to create an exceptionally compact terminal. The electronics, battery and insulation had to fit into as little space as possible, whilst the antenna surface area had to be large enough to receive the satellite signal. Power consumption had to be minimised for optimal standby and operational time, and the battery had to be as small and light as possible. Overheating also had to be avoided by allowing for sufficient heat dissipation and designing signal processing algorithms and electronics for minimal heat generation. When choosing materials, the engineers had to balance mass, robustness and heat conductivity.

The Nera team’s efforts have resulted in the world’s smallest mobile data satellite communications terminal. The Nera WorldPro 1000 weighs less than 1 kg and measures only 15 x 20 cm. It fits easily into the spare compartment of a computer bag and even in the pocket of a military uniform.

Durable Design

Designing a communications terminal that tolerates extensive travel and operation in extreme conditions is very different from developing a modem for an office-bound computer.

Indoor Comfort – Outdoor Use

A BGAN terminal needs to be able to handle temperatures ranging from winter in the Arctic to summer in the Sahara. It has to cope with sandy deserts and humid rain forests, and everything in-between. The weather aspect puts requirements not only on the terminal’s ability to transmit and receive signals, but also on the user’s ability to operate the terminal. Direct sunlight on LED indicators and the computer screen makes it difficult to use the laptop and to monitor the status of the terminal. In cold climates it is mainly a matter of personal comfort. Typing on a keyboard in minus 30 centigrade quickly gets chilly. Low temperatures also shorten battery life.

Outdoor usage can also have implications for safety and security. In hostile situations, working outside can attract unwanted attention and present a life-threatening situation. In other regions, expensive equipment put up in a public place can easily draw thieves.

Despite these issues, a satellite antenna needs to have free line of sight to a satellite in order to maintain the signal. So some of the equipment has to be located outdoors.



The Nera WorldPro 1000 easily fits in a small bag.

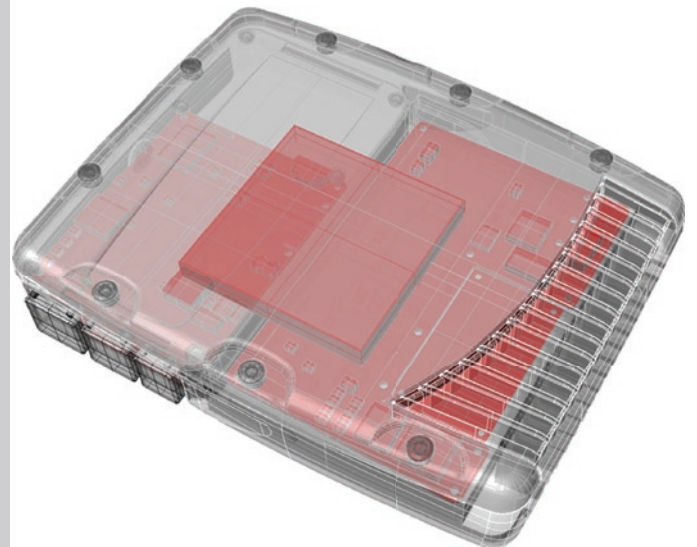

Computer-generated image of the Nera WorldPro 1000 showing the one-patch antenna.

The Logical Solution

The engineers at Nera found a very logical solution to these apparently conflicting considerations. They simply designed the Nera WorldPro 1000 as two units. All the interfaces for connecting to a computer and handset, as well as the operational status indicators are contained in the interface unit. The interface unit also houses the subscriber's SIM card and the battery. None of these components need a direct connection to the satellite and they all work just as well indoors as outdoors.

The antenna patch itself, along with elements used to operate the antenna, such as the RF circuitry board and the built-in GPS, need to be located outdoors. Nera placed these functions in an antenna unit which can be separated from the interface unit by up to 20 metres. The two units are connected by a cable which transmits signals and serves to power the antenna from the interface unit. In this way, the Nera engineers made sure that only a single cable is required.

Consequently, the user can place the interface unit indoors and work on the phone or the computer, while the antenna unit is left outdoors in free line of sight to the satellite. The user does not experience any disturbing sunlight or excessive cold, keeps the SIM card safe and preserves battery life at an optimal temperature.

Naturally, the two units can also be joined as one, providing flexibility in less critical user situations and keeping the terminal as compact as possible for travel. This enables flexible working without the need for additional components.

Robust Interior And Exterior

Constant travel and rough rides, outdoor use, temperature swings, the fast pace of field operations – the BGAN user scenarios demand optimal durability.

Durability is therefore a key consideration when selecting materials, locating components and designing casing. Round corners, no protrusions and covered connectors are essentials. Moreover, every component should be designed to fall apart on impact, not break. Then the user can simply put the unit back together again on location, as opposed to return it to a repair centre.

The Nera WorldPro 1000 can be dropped half a meter onto concrete without breaking. It operates in temperatures from minus 20°C to plus 50°C and in environments of up to 95% humidity. The terminal conforms to sealing class IP44, meaning it will work in a sandstorm and in heavy rain.

Complete Voice and Data

The 21st century is the age of data communications. Yet, the enormous increase in data applications has not made voice telephony any less important, certainly not for the typical BGAN user. When handling critical situations in remote areas, a voice call is still often the easiest and quickest way to communicate.

A key feature of BGAN is that voice and data communications can take place simultaneously via the same terminal. Inmarsat has also developed a new and improved voice codec in order to deliver toll-quality voice.



Working indoors in a safe and comfortable environment.



Temperature testing of the Nera WorldPro 1000 ensuring robust performance.

Handset Integration

In order to leverage the BGAN voice capabilities to the full, Nera has delivered a complete package for both voice and data communications.

The Nera WorldSet is an ISDN handset customised for the Nera BGAN terminal. Users can also read and write text messages (SMS) from the handset, as an alternative to sending e-mails. Optimised for convenience, there is also a loudspeaker function for hands-free operation and the option to connect the handset to recording equipment, external amplifiers, a headset or a wired earpiece.

Additionally, the Nera WorldSet enables the user to configure BGAN service parameters such as QoS independently of the BGAN man-machine interface on the computer. This leaves the USB port on the terminal available for connecting to specialised peripheral equipment.

Moreover, this option positions BGAN not only as a data service with a voice add-on, but as a powerful voice service in its own right and an alternative to handheld voice services. For BGAN subscribers, this removes the need for a separate subscription to a handheld satellite voice service and makes it possible to take advantage of BGAN when travelling without a computer.

Wireless Option

For the BGAN user working outdoors or from temporary bases, wireless communication is ideal. Nera has therefore given the Nera WorldPro 1000 a Bluetooth option. This meant that the Nera engineers had to overcome the interference problems between the I-4 system and the Bluetooth frequency band. The Bluetooth interface enables the use of both a Bluetooth handset and a wireless connection from the terminal to the computer.

Standard Interfaces

In order to imitate a 'normal' office situation, Nera has equipped the Nera BGAN terminal with standard interfaces for connection to a computer. The dual-port function on the USB connection allows several programmes to run simultaneously via the single USB port. This is particularly useful when transmitting data at the same time as managing the terminal via the man-machine interface on the computer.

It is also key that users of the Nera WorldPro 1000 can connect to whatever peripheral equipment they have at hand. Therefore, the Nera WorldPro 1000 works with any third-party ISDN handset, in addition to the BGAN-optimised handset developed by Nera.'

Performance & Applications

Broadband communication for bandwidth-hungry applications is at the heart of the BGAN proposition: BGAN was invented to allow professionals operating from makeshift 'offices' on the road to take part in the telecommunications upsurge.

A BandWidth - Size Trade-Off

Inmarsat's powerful I-4 satellite system can deliver up to 500 kbps. To send and receive at this rate, a satellite antenna with six patches is required. However, a terminal with a six-patch antenna will have half the opening angle of a one-patch antenna and require nearly three times the surface area. The difference in bandwidth is only some



Configuring and controlling the Nera WorldPro 1000 directly from the handset.

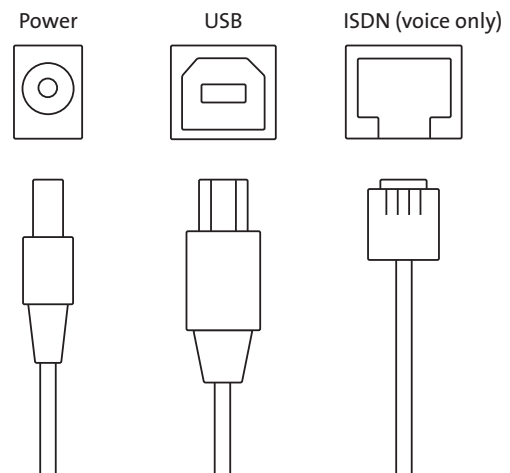

Standard interfaces on the Nera WorldPro 1000.

100 kbps in the receive direction. Considering this trade-off, Nera has prioritised portability and ease of use in its BGAN solution.

The Nera WorldPro 1000 receives at 384 kbps and transmits at 240 kbps. These rates are similar to terrestrial broadband and five to six times better than existing mobile satellite services. For the majority of BGAN applications used by the Nera WorldPro 1000 target segments, the difference in bandwidth delivered by a one-patch versus a six-patch antenna will have little noticeable effect and is outweighed by the gain in user-friendliness.

All BGAN background data services are always-on in the same way as terrestrial DSL and cable services. As a result, an end user can let the service receive calls and e-mail. This is a great improvement over having to dial up at regular intervals to check for incoming messages.

Streaming Voice For Multiple Users

Streaming services provide guaranteed quality of service, lending themselves to mission-critical applications. With a streaming rate of 64 kbps, BGAN provides high-quality Internet radio, and is sufficient for most crypto applications used by defence and governmental organisations.

Streaming can also be used for voice calls. With a 64 kbps streaming service, up to five of simultaneous voice-over-IP calls are possible.

Easy To Use

Humanitarian organisations are experts at providing aid in disaster areas and rebuilding communities. They should not have to be communications specialists or spend time learning how to operate technical devices. And it is generally unrealistic to dispatch an IT professional with the team when moving to a new location. That's why the BGAN terminal is designed for operation without any training or technical expertise.

Equally important, an urgent assignment rarely allows ample time to set up the equipment. Hence, the BGAN terminal can be rapidly started up for instant use.

Instant Communications

The lack of a compass on the Nera WorldPro 1000 indicates Nera's confidence in the terminal's simple set-up procedure.

Set-up time for a satellite communications terminal is the time it takes to lock the terminal onto the satellite. This depends on the opening angle of the antenna; wider angles allow quicker set up. A one-patch antenna has the largest opening angle of any mobile satellite communications terminal. Even at the edge of its beam, the Nera WorldPro 1000 has an opening angle of 60°, double that of most six-patch antennas.



Connecting Antenna Unit of the Nera WorldPro 1000 for indoor use.

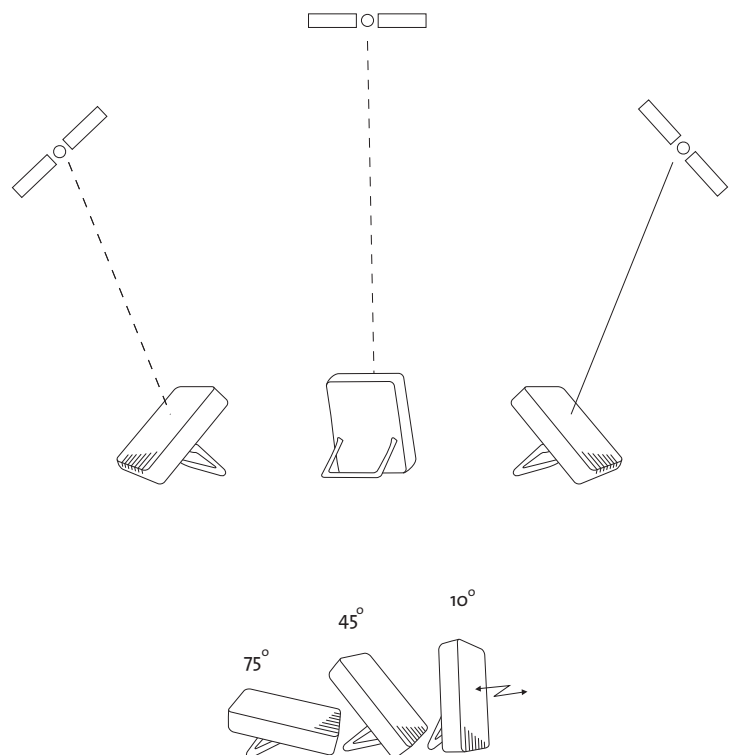

The 60° opening angle of the Nera WorldPro 1000 makes antenna pointing extremely easy.

Conserving Power

For a user in a remote location the lack of a reliable power supply and charging possibilities makes battery life a key issue.

Even though the Nera WorldPro 1000 can locate a communications signal as long as the terminal is anywhere within the 60° angle, minimum battery power is consumed when the terminal points directly towards the satellite. An automatic search programme is therefore initiated as soon as the terminal is turned on. Using visual and audible indicators, it guides the user towards an optimal communications signal within seconds.

The Nera WorldPro 1000 also employs adaptive coding to optimise utilisation of both satellite and terminal resources.

The Nera WorldPro 1000's sleep mode switches off most functions when the terminal is not active, and an a priori known reception scheme means the terminal effectively turns itself off for brief moments even during active transmission or reception.

Finally, as the current generation of wi-fi technology is not optimised for battery-operated equipment, Nera decided against including a wi-fi interface on the Nera WorldPro 1000.

Conclusions

Professional users of BGAN services operate in exceptional circumstances, which place exceptional demands on the way they communicate.

By developing the Nera WorldPro 1000 and the Nera WorldSet in close cooperation with key users, Nera has been able to incorporate features and functions that optimise the terminal for critical use in remote locations. In particular, the terminal is tailored to meet the following key requirements;

- High bandwidth
- Complete voice and data solution
- Flexible indoor and outdoor use
- Ease of use on location
- Minimal size and weight for ultimate mobility
- Robustness

The result of incorporating a set of differing needs into a single solution, the Nera WorldPro 1000 is a communications tool optimised for highly demanding professional users carrying out critical tasks from frequently changing locations.



The Nera WorldPro 1000 delivers voice services globally, with a wireless connection from the handset to the terminal.

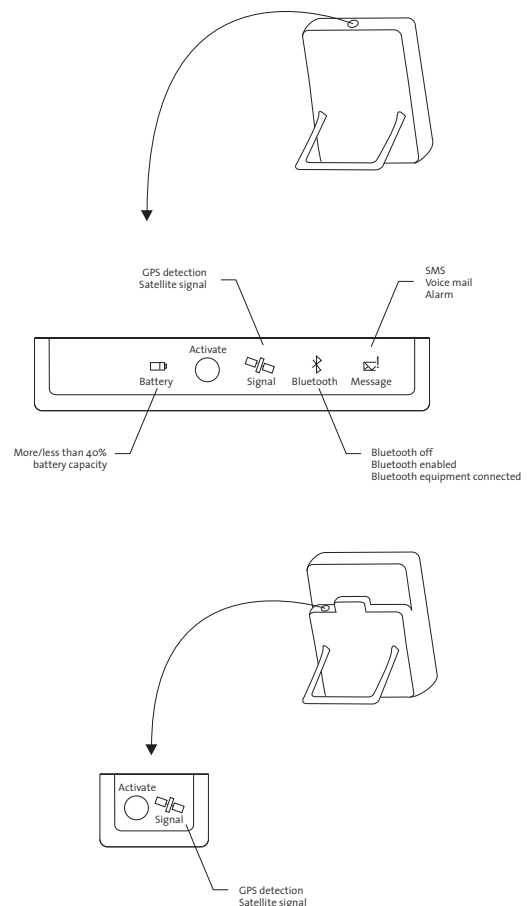

Indicators on the Interface Unit and Antenna Unit of the Nera WorldPro 1000.

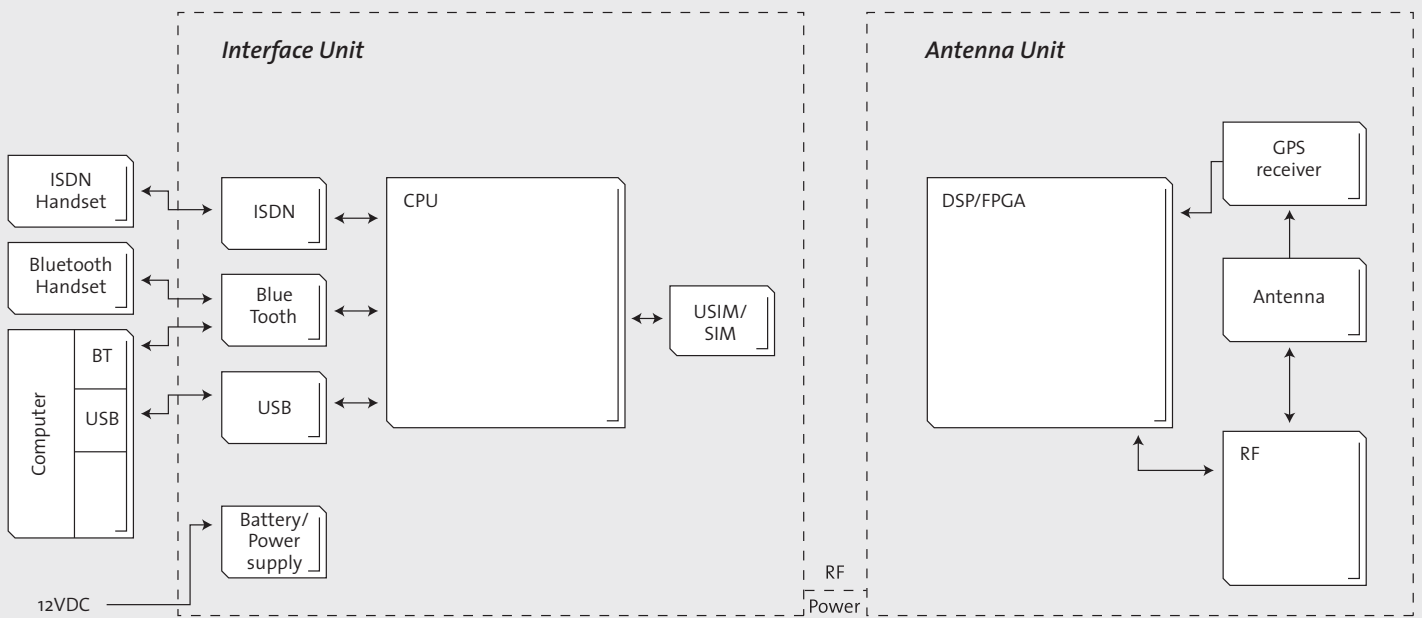

A fully-owned subsidiary of Nera, Nera SatCom is the chief supplier of products and solutions for the Inmarsat satellite system and a leading manufacturer of equipment based on the DVB-RCS broadband via satellite standard.

Nera SatCom AS
Bergerveien 12
1375 Billingstad, Norway
www.neraworld.com

Distributor

Version 1.0. Text and production: Nera SatCom AS. Photographs: James Hudson and Nera Satcom AS. Design and illustrations: Gazette as.

GLOSSARY

BGAN	Broadband Global Area Network	QoS	Quality Of Service
BT	Bluetooth	RF	Radio Frequency
CPU	Central Processing Unit	SIM	Subscriber Identification Module
DSL	Digital Subscriber Line	SMS	Short Messaging Service
DSP	Digital Signal Processor	USIM	Universal Subscriber Identification Module
DVB-RCS	Digital Video Broadcast - Return Channel via Satellite	USB	Universal Serial Bus
FPGA	Field Programmable Gate Array	VDC	Voltage Direct Current
GPS	Global Positioning System		
ISDN	Integrated Services Digital Network		
kbps	kilo bits per second		
LED	Light Emitting Diode		

